



THE MOBILE WELDING CELL FOR THE CRAFT BUSINESS: ***SIMPLE, LOW-BUDGET, SAFE***



**AWAKEN THE
WELDER
IN YOU!**

EASYARC

Advantages

EASYARC

The mobile installation concept for automated welding

- **Mobile compact design:**
space-saving, flexible and reasonably-priced
- **Easy operation with OTC Easy Teach control:**
minimal time required to create the welding program, even without elaborate training
- **Stable and precise welding robot:**
physical relief for employees and ensures optimized, consistent welding quality
- **Safety technology in accordance with CE standards:**
Electrically monitored, lightweight protective housing safeguards from unauthorized access and glare effects

Setting up

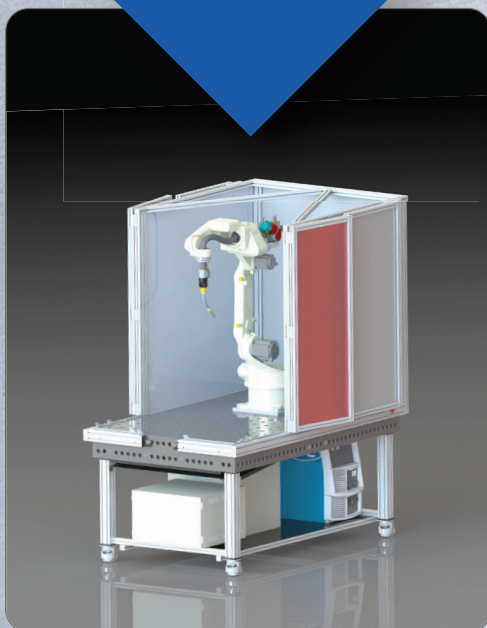

Loading

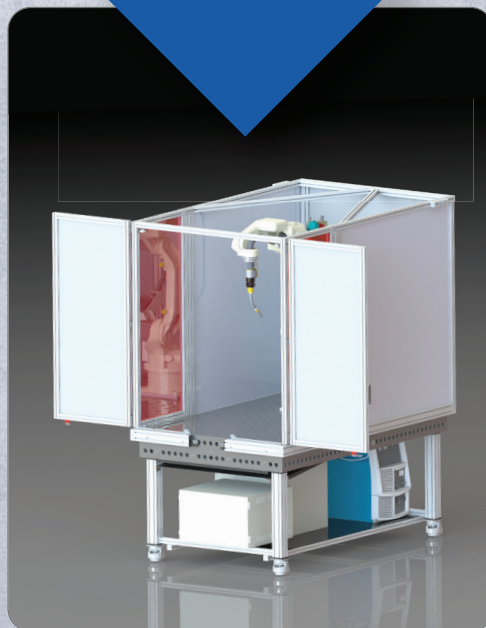

Welding

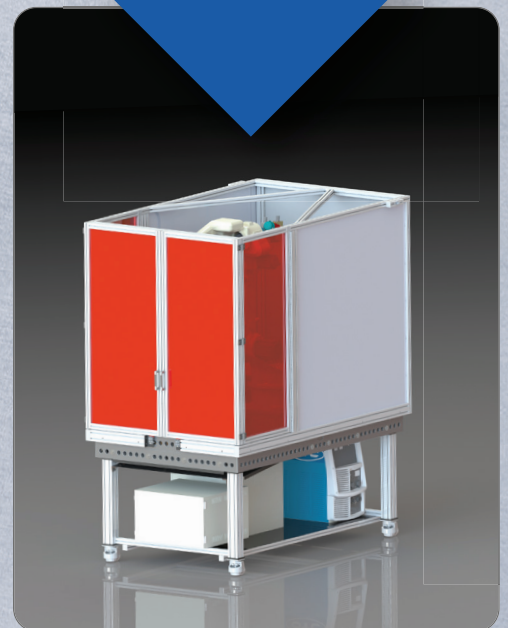

Features and characteristics

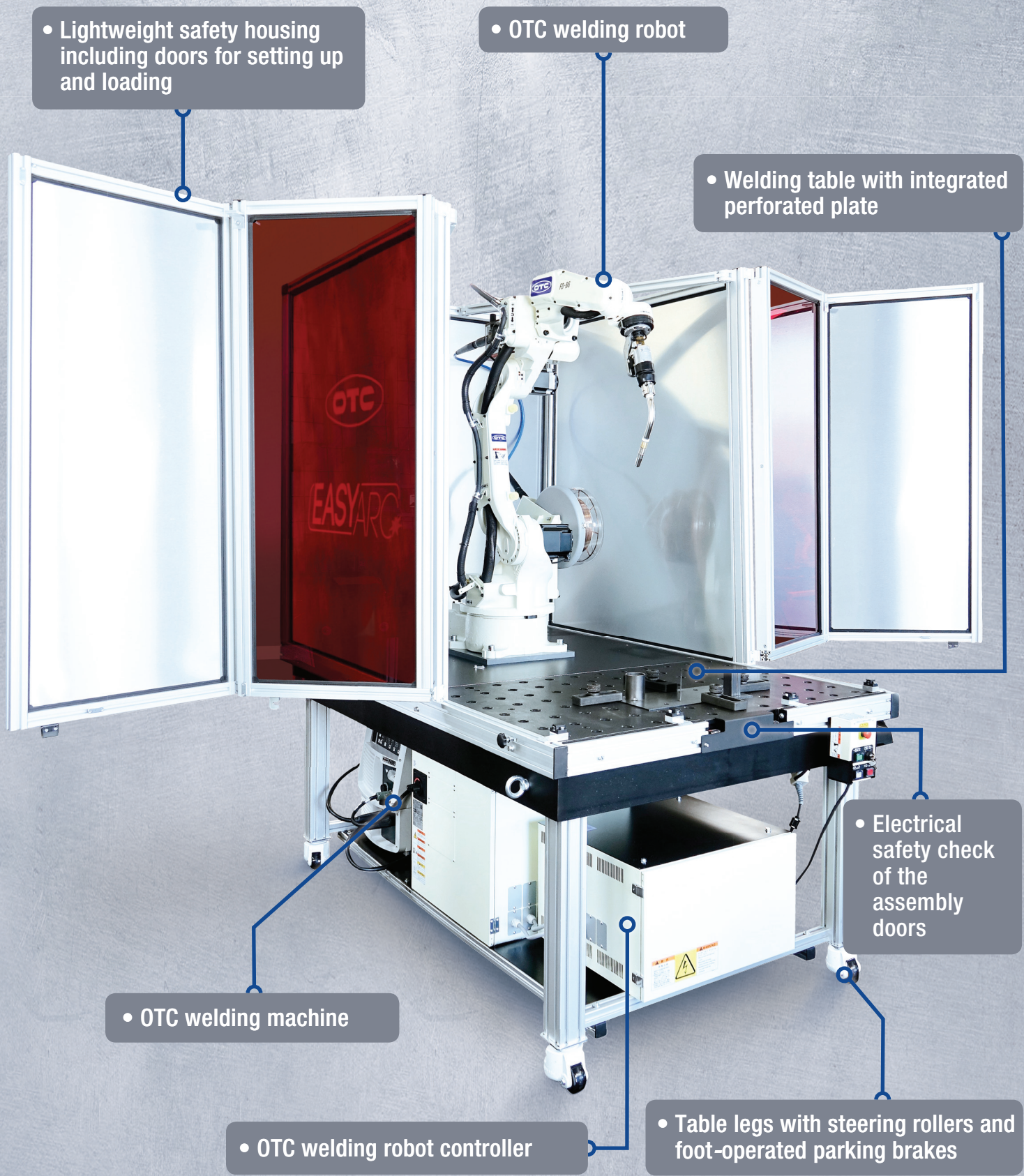

EASYARC Simple, low-budget, safe

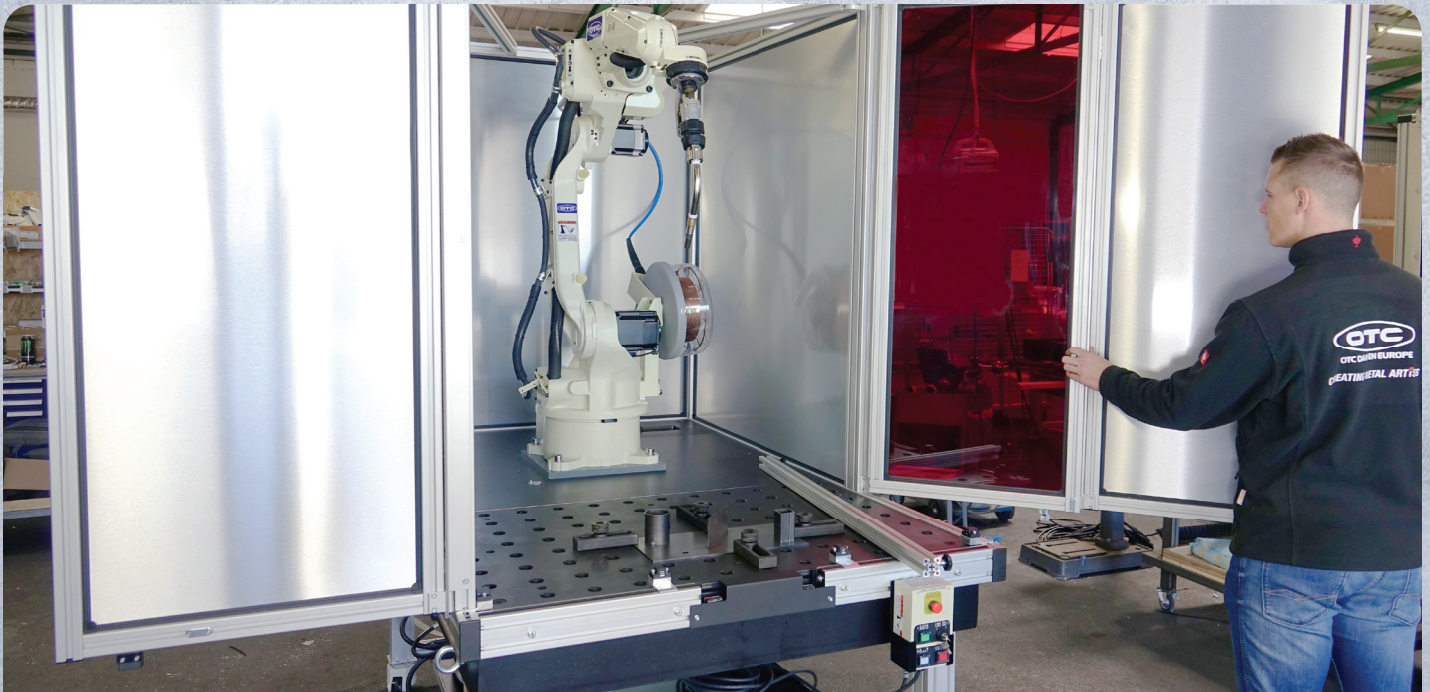

1

- Safety housing with aluminum sheet reinforcement, large opening and foldable side elements - seen here in setup mode



2

- Creating a program on the component using the Easy Teach mode

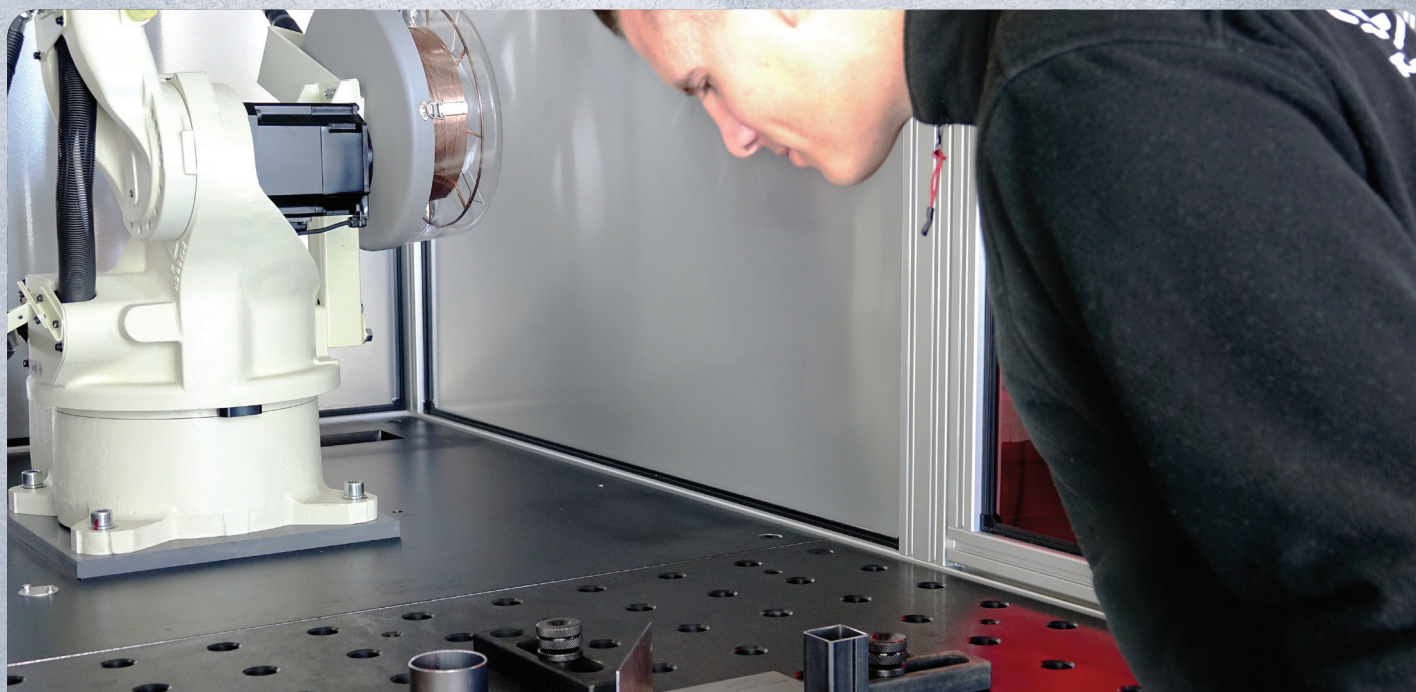

3

- Welding table prepared for holding clamping elements - here, the operator is shown during the mounting phase



4

- Automatic welding process with the machine closed - operator observes the process through the safety windows

Configuration

EASYARC 01 – *MIG/MAG package*

Compact turnkey welding robot station with welding technology

Basic equipment

- 3D welding table with intelligent system grids for clamping and positioning the workpieces
- Fully assembled and CE-compliant documentation
- Welbee P400 welding machine (gas-cooled inverter pulse power source)
- OTC safety technology with monitoring unit (RMU) and housing
- Six-axis robot, FD-B6, with integrated cable routing for optimal accessibility
- OTC robot welding torch with forced shutdown



Option 01

- Welbee P500L welding machine (water-cooled inverter pulse power source)



Option 02

- Horizontal rotary positioner, A2-1PB250, including synchro-motion software and integration in the Easy Teach control system

Layout and dimensions

EASYARC 01 – MIG/MAG package

Basic equipment for MIG / MAG welding with Welbee P400 welding machine

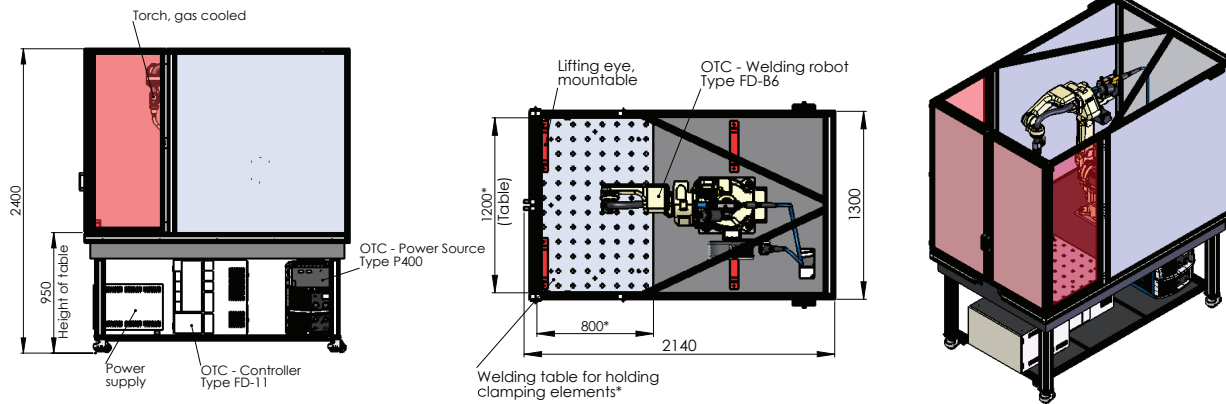

Option 01 for MIG / MAG welding with Welbee P500L welding machine

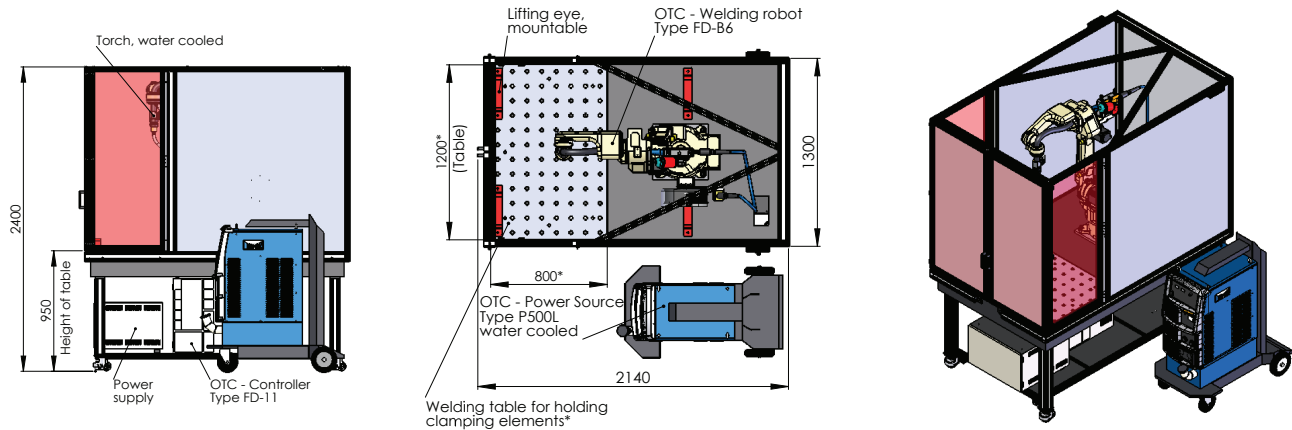

Option 02 for MIG / MAG welding* with horizontal rotary positioner

*Optionally with Welbee P400 or P500L welding machine

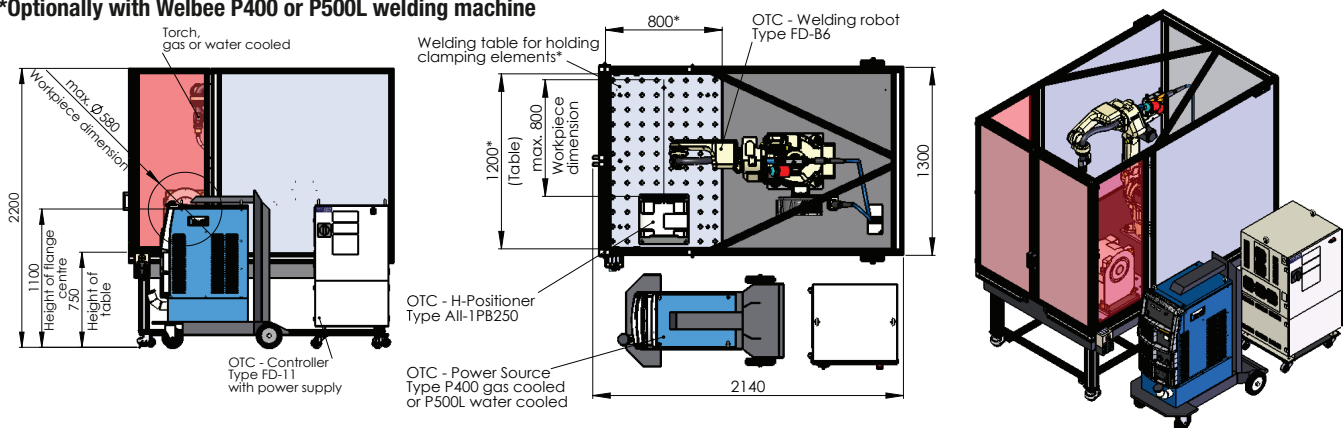

Configuration

EASYARC *02 – TIG package*

Compact turnkey welding robot station with welding technology

Basic equipment

- 3D welding table with intelligent system grids for clamping and positioning the workpieces
- Fully assembled and CE-compliant documentation
- Welbee A350P welding machine (water-cooled inverter pulse power source)
- OTC safety technology with monitoring unit (RMU) and housing
- Six-axis robot, FD-V8 for maximum flexibility
- OTC robot welding torch with 3D forced shutdown



Option 01

- Push-pull system for feeding welding wire into the weld pool



Option 02

- Horizontal rotary positioner, A2-1PB250, including synchro-motion software and integration in the Easy Teach control system

Layout and dimensions

EASYARC 02 – TIG package

Basic equipment for TIG welding with Welbee A350P welding machine

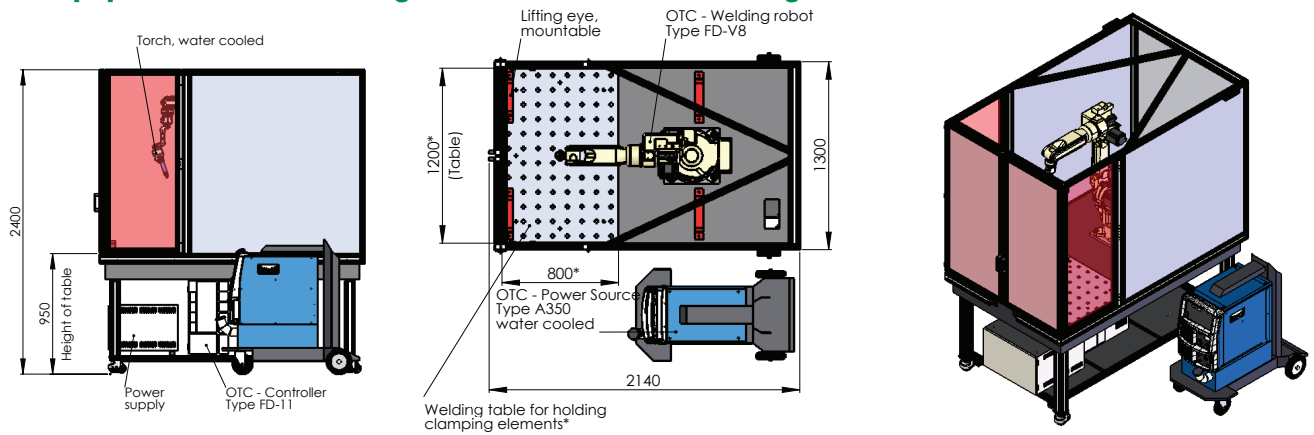

Option 01 for TIG welding with cold wire (push-pull system)

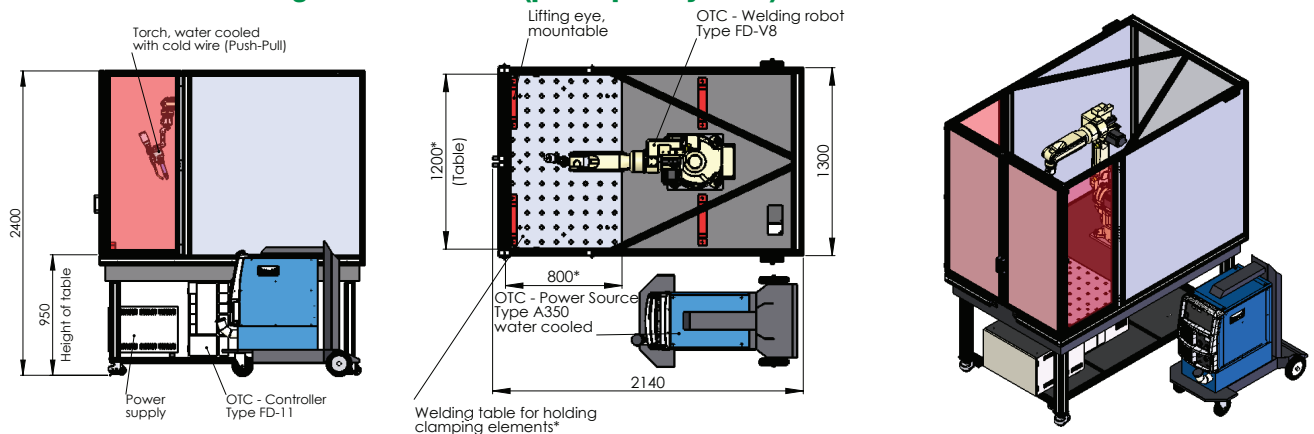

Option 02 for TIG welding* with horizontal rotary positioner

*Optionally with or without cold wire (push-pull system)

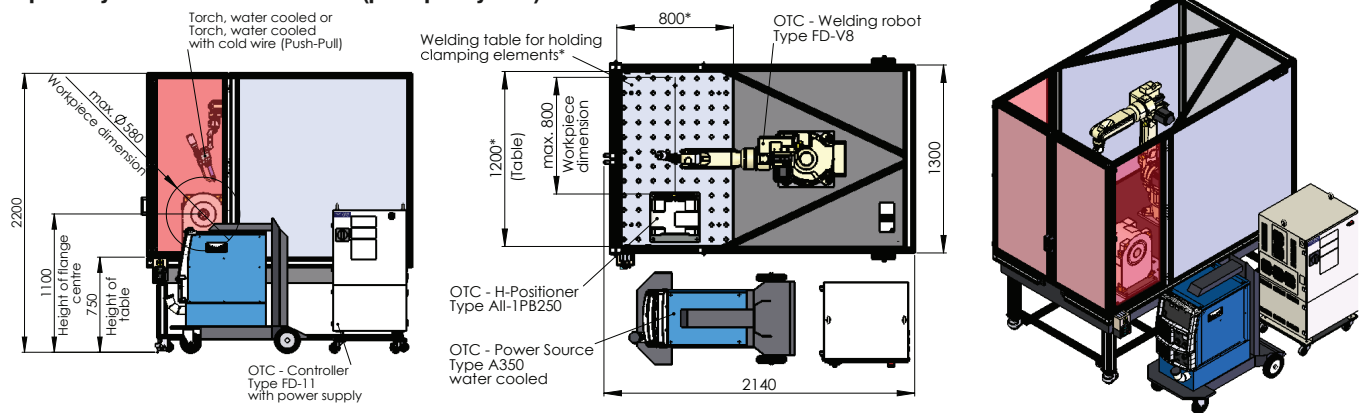

Technical specifications

Robot



Model	FD-B6	FD-V8
Kinematics	Vertically articulated robot	Vertically articulated robot
Number of axes	6	6
Workspace (P-point)	R 1,445 mm	R 1,437 mm
Maximum load	6 kg	8 kg
Repeat accuracy (see note 1)	± 0.08 mm	± 0.08 mm
Drive system	AC servo motor	AC servo motor
Ambient temperature/humidity	0 ~ 45°C, 20 ~ 80%	0 ~ 45°C, 20 ~ 80%
Weight	145 kg	140 kg
Maximum load on upper arm	10 kg	10 kg
Position information	See note 2	See note 2
Installation position of the vertically articulated robot	F, W, C	F, W, C

Note 1: The indicated value is the result of numerous repetitions of automated operations under stable conditions, during operations of the robot with maximum load. The repeat accuracy (repeatability) refers to the covered path. Repeatability with respect to the point is ± 0.2 mm.

Note 2: The position information is protected by the battery-powered memories inside the manipulator.
F = floor / W = wall / C = ceiling

Welding machines



Model	<i>We/bee</i>	P400 (MIG/MAG)	P500L (MIG/MAG)	A350P (TIG)
Execution		Gas-cooled	Water-cooled	Water-cooled
Supply voltage (± 15%)		3 x 400 V / 50 Hz	3 x 400 V / 50 Hz	3 x 400 V / 50 Hz
Max. rated power		18.2 kVA	25 kVA	12.7 kVA (AC) / 12.2 kVA (DC)
Welding current		30–400 A	30–500 A	5–350 A (AC) / 2–350 A (DC)
Welding voltage		12–34 V	12–39 V	24 V
Welding current/ duty cycle	30 %	400 A	500 A	350 A (AC) / 350 A (DC)
	60 %	400 A	500 A	350 A (AC) / 320 A (DC)
	100 %	370 A	410 A	270 A (AC) / 300 A (DC)
Type of protection/cooling		IP 23 / F	IP 23 / F	IP 23 / F
Switching steps		Continuously variable	Continuously variable	Continuously variable
Dimensions L x W x H		710 x 395 x 592 mm	710 x 395 x 762 mm	710 x 395 x 592 mm
Weight		62 kg	62 kg	68 kg

Welding table

OTC Welding Table

- Made of high-quality steel S355J2+N, plasma-nitrided and coated
- Dimensions of the whole table: (D*W) 2.000*1.200mm
- Dimensions of the perforated plate: (D*W) 1.200*800mm
- Table height depends on selected variant
- Table legs with steering rollers and foot-operated parking brakes
- Load capacity approx. 1.000 kg
- Weight approx. 600 kg
- Different hole diameters available:
 - Drilling hole \varnothing 28mm in a 100*100mm grid
 - Drilling hole \varnothing 22mm in a 100*100mm grid
 - Drilling hole \varnothing 16mm in a 50*50mm grid

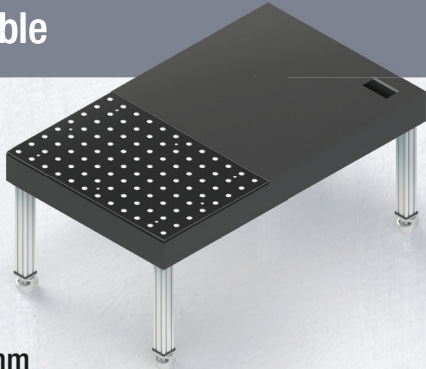

Horizontal turning positioner

OTC positioner PB

- Enables fully synchronized operation with FD-series robots
- The central hole in the flange plate is designed for conducting media
- Maximum load 250 kg
- Rotational speed 26° per sec.
- Torque 205 Nm
- Repeat accuracy ± 0.1 mm
- Weight 110 kg

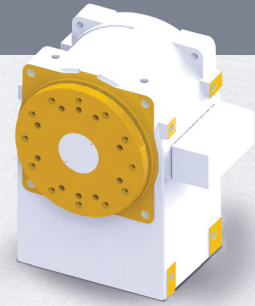

Welding torches

Welding torch RT3500H



(gas-cooled changeable neck system, 1.0 mm steel)

- Torch neck: 45°
- Maximum load: 350 A / gas-cooled
- Collision protection: B-type, integrated

Welding torch RTW5000H

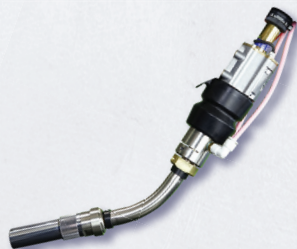

(water-cooled changeable neck system, 1.2 mm steel)

- Torch neck: 45°
- Maximum load: 500 A / water-cooled
- Collision protection: B-type, integrated

Welding torch WH400

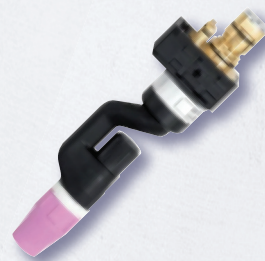

- Torch neck: 0°
- Maximum load: 400 A / water-cooled
- Collision protection: type CAT2-XL

Welding torch WH-PP-400

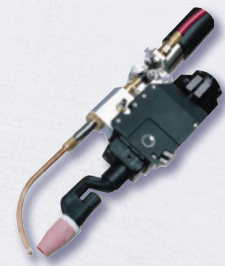

(including cold wire)

- Torch neck: 0°
- Maximum load: 400 A / water-cooled
- Collision protection: type CAT2-XL

OTC DAIHEN EUROPE GmbH

Krefelder Str. 675–677 · 41066 Mönchengladbach

Tel.: +49 (0) 21 61 / 69 49 7–100

Fax: +49 (0) 21 61 / 69 49 7–101

info@otc-daihen.de · www.otc-daihen.com

Technical changes and errors reserved. Similar pictures.

2020/08

Member of DAIHEN Group

DAIHEN

